

DEPARTMENT OF THE ARMY TECHNICAL MANUAL

FIELD AND DEPOT MAINTENANCE MANUAL

PERISCOPE M37

Headquarters, Department of the Army, Washington, D.C.

14 January 1963

		Paragraph	Page
CHAPTER	1. INTRODUCTION		
Section	I. General		
	Scope	1	2
	Maintenance allocation and parts	2	2
	Maintenance techniques	3	2
	Forms, records, and reports.	4	2
	II. Description and data		
	Description	5	3
	Data	6	3
CHAPTER	2. TOOLS AND EQUIPMENT		
	General	7	6
	Common tools and equipment.	8	6
	Special tools and equipment.	9	6
CHAPTER	3. INSPECTION		
Section	I. General		
	Scope	10	7
	Purpose	11	7
	Forms and reports	12	7
	Modification work orders.	13	7
	II. Inspection in the hands of troops and in ordnance maintenance shops		
	General	14	7
	Inspection	15	8
CHAPTER	4. REPAIR AND OVERHAUL		
Section	I. General		
	Scope	16	9
	Maintenance technique.	17	9
	References	18	9
	II. Repair and overhaul of periscope M37		
	Scope	19	9
	Disassembly and assembly.	20	9
	Final inspection	21	10
CHAPTER	5. PROCESSING AND PACKAGING		
	Specifications	22	11
	Optical components	23	11
APPENDIX.	REFERENCES		12

CHAPTER 1

INTRODUCTION

Section I. GENERAL

1. Scope

a. This manual contains instructions for the field and depot maintenance of periscope M37.

b. These instructions are used in conjunction with and are supplementary to those in the operator's or organizational maintenance manual. Instructions for operation, lubrication, and operator's maintenance are in TM 9-2350-215-10. Instructions for maintenance including installation and removal procedures, as well as tests and adjustments after installation, are in TM 9-2350-215-20. It may be necessary to refer to these manuals for complete procedures.

c. A description of the item, inspection procedures, and repair and overhaul operations are presented in this manual.

d. The appendix contains a list of current references, including supply and technical manuals, forms, and other available publications applicable to periscope M37.

e. This first edition is being published in advance of complete technical review. Any errors or omissions will be forwarded on DA Form 2028 direct to the Commanding Officer, Frankford Arsenal, ATTN: SMUFA-3100, Philadelphia 37, Pa.

2. Maintenance Allocation and Parts

a. Field and depot maintenance responsibilities are limited to those specified in the maintenance allocation chart in TM 9-2350-215-20.

b. Repair parts authorized to field and depot maintenance units are listed in TM 9-1240-315-35P. Unlisted parts will be supplied, if available, when complete justification is included.

3. Maintenance Techniques

a. The maintenance technique, IROAN (Inspect and Repair Only As Necessary) will be used to restore this materiel to serviceable condition.

b. IROAN is the systematic isolation and remedy of a malfunction or defective component through tests, diagnosis, and singular repair. No segment of the materiel is disassembled before the definite need for disassembly has been established.

4. Forms, Records, and Reports

a. General. Responsibility for the proper execution of forms, records, and reports rests upon the commanding officers of all units maintaining this equipment. However, the value of accurate records must be fully appreciated by all persons responsible for their compilation, maintenance, and use. Records, reports, and authorized forms are normally utilized to indicate the type, quantity, and condition of materiel to be inspected, to be repaired, or to be used in repair. Properly executed forms convey authorization and serve as a record of work performed. The forms, records, and reports establish the work required, the progress of the work, and the status of the materiel upon completion of its repair.

b. Authorized Forms. The forms generally applicable to units maintaining this materiel are listed in the appendix. For instructions on use of these forms, refer to FM 9-3 and 9-4. For a listing of all forms, refer to DA Pam 310-2.

c. Field Report of Accidents. The reports necessary to comply with the requirements of the Army safety program are prescribed in detail in AR 385-40. These reports are required whenever accidents involving injury to personnel or damage to materiel occur.

d. Equipment Improvements Recommendations (EIR's) (formerly Unsatisfactory Equipment Reports). All EIR's will be in accordance with TM 38-750.

e. Reporting Receipt of Defective Material. All reports will be in accordance with TM 38-750.

Section II. DESCRIPTION AND DATA

5. Description

a. Periscope M37 (fig. 1) is used as a vision device in 105-mm gun full tracked combat tank M60A1. The pins, on either side of the housing near the cover, act as trunnions for mounting it in the vehicle.

b. A segment attached on the right side of the housing (fig. 2) is secured by a knob. Loosening the knob permits the periscope to be tilted in elevation or depression. Two windows and two mirrors are bonded to the plastic body. A housing containing the body has a crash pad secured to the lower end.

6. Data

a. *Physical Characteristics.*

Length (including crash pad) 15-1/2 in.
Width (including crash pad) 8-3/4 in.
Depth (including crash pad) 3-1/8 in.
Weight 16 lb

b. *Optical Characteristics.* This periscope is of the solid plastic type, single power of magnification. Field of view 26 degrees vertical and 72 degrees horizontal. The optical characteristics are not considered pertinent beyond the inspection of the materiel at time of manufacture, in accordance with MIL-P-46329 (ORD) dated 30 January 1962 and/or the amendment which is to include periscope M37.

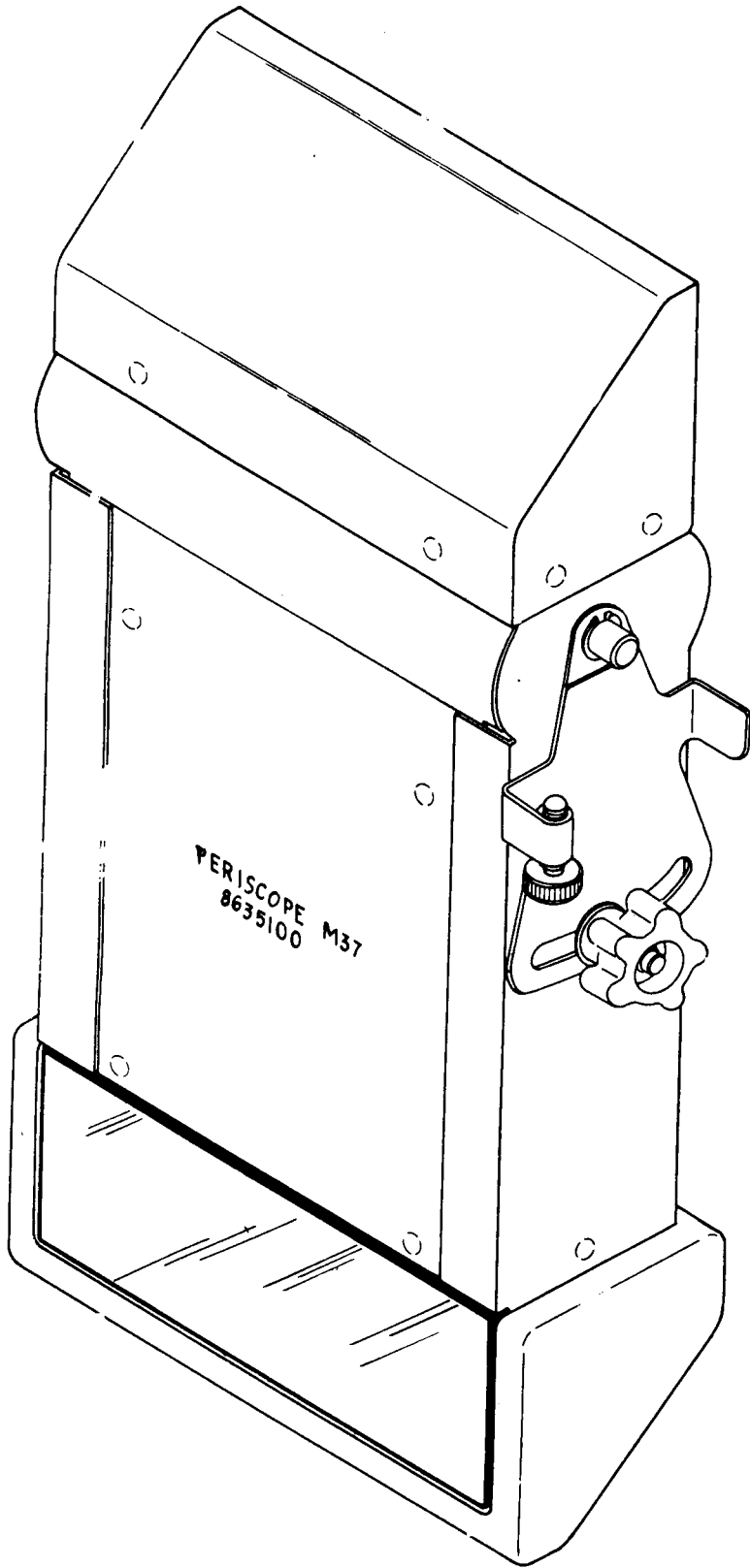
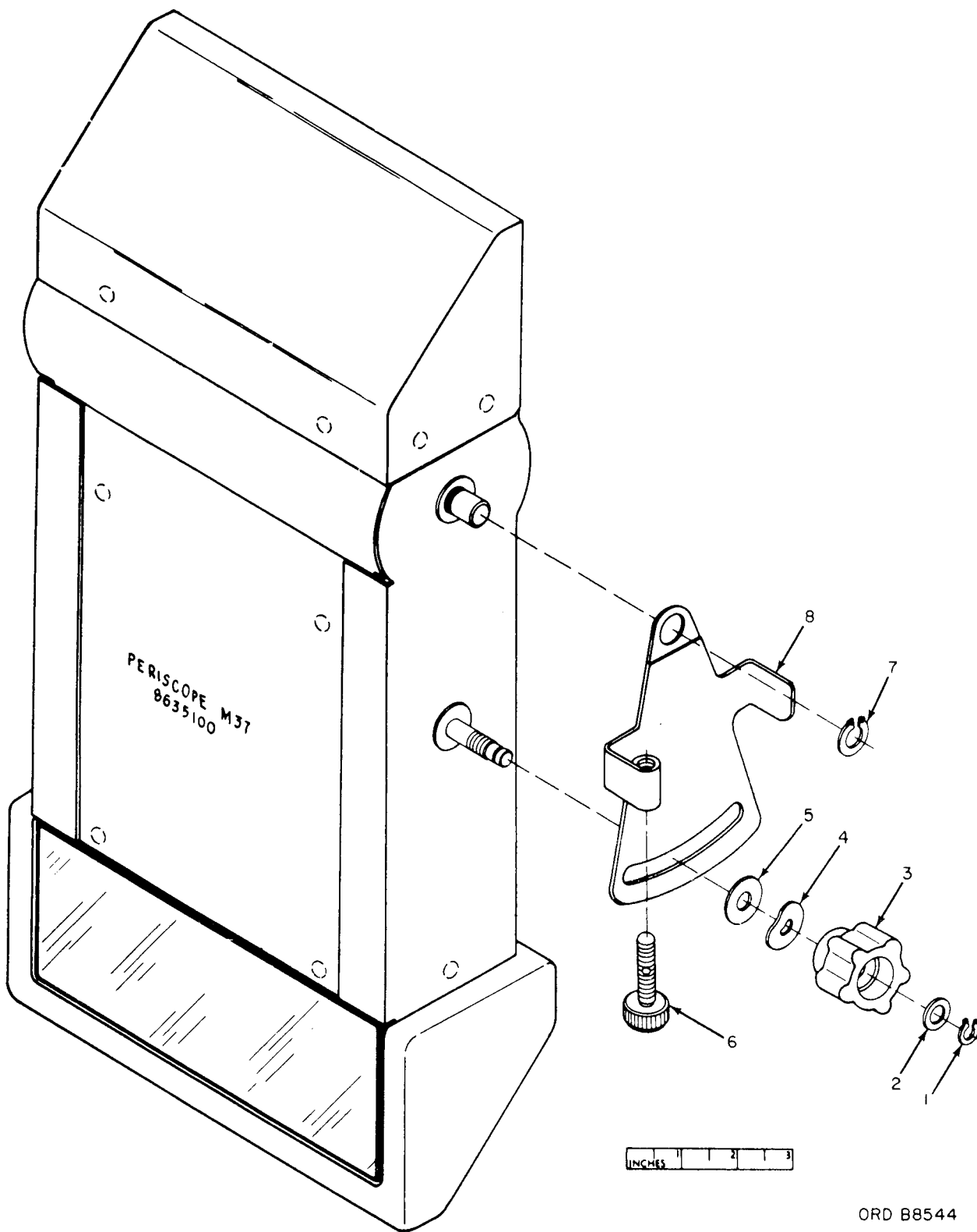

Figure 1. Periscope M37.

ORD B6803A



- 1-Ring 5340-281-3605
- 2-Washer MS15795-310
- 3-Knob 5355-081-7191
- 4-Washer 5310-638-3633

- 5-Washer MS15795-313
- 6-Screw 5305-081-7193
- 7-Ring 583035
- 8-Segment 8635080

ORD B8544

Figure 2. Periscope M37 - partial exploded view.

CHAPTER 2

TOOLS AND EQUIPMENT

7. General

Tools and equipment over and above those available to the using organization are supplied to field and depot maintenance units for repair and overhaul of periscope M37.

8. Common Tools and Equipment

Standard and commonly used tools and

equipment having general application to this materiel are authorized for issue by tables of allowance and tables of organization and equipment.

9. Special Tools and Equipment

No special tools and equipment are authorized or required for field and depot maintenance operations.

CHAPTER 3

INSPECTION

Section I. GENERAL

10. Scope

This chapter provides specific instructions for the technical inspection by Ordnance maintenance personnel of periscope M 37 either in the hands of troops or when received for repair in an Ordnance field or depot maintenance shop.

11. Purpose

a. *Inspection in the Hands of Troops.*

- (1) Insure that preventive maintenance services are being performed and are effective.
- (2) Ascertain the serviceability, completeness, or readiness of Ordnance materiel in the hands of troops.
- (3) Render any necessary assistance to the using organization.
- (4) Provide instructions for organizational supply and maintenance.
- (5) Determine the most prevalent deficiencies in maintenance of materiel.
- (6) Anticipate unusual supply demands.
- (7) Make a record of condition of materiel in the hands of troops.

b. *Inspection in the Repair Shop.*

- (1) Determine the nature of the required repair.

- (2) Determine the extent of repair required to return the materiel to serviceability in order that its disposition may be planned.
- (3) Assure that work in process is being performed properly.
- (4) Insure that work performed complies fully with approved standards.

12. Forms and Reports

Authorized forms and reports for technical inspections by field and depot maintenance personnel are listed in the appendix. Preventive maintenance logs, if available, will be examined to determine the maintenance background of the materiel.

13. Modification Work Orders

All urgent modification work orders must have been applied. Check to see that no unauthorized alterations have been made, and that no work beyond the authorized scope of the unit is being attempted. Check DA Pam 310-4 and the current modification work order files to determine applicable modification work orders.

Section II. INSPECTION IN THE HANDS OF TROOPS AND IN ORDNANCE MAINTENANCE SHOPS

14. General

This section provides specific instructions for the technical inspection by ordnance field and depot maintenance personnel of periscope M37 in the hands of troops, or inspection prior to disassembly when received for repair in field

or depot maintenance shops. In general, if the periscope is complete and performs its intended function properly, if all modification work orders, classified as urgent have been completed the periscope M37 may be considered serviceable. Inspection

in the repair shops upon receipt of the materiel turned in for repair determines the cause of unserviceability, the amount of work required to return the materiel to serviceability, and the amount of supplies, parts, or assemblies necessary to accomplish the repairs.

15. Inspection

a. Examine the periscope to insure all component parts are present. Refer to TM 9-1240-315-35P.

b. The general appearance of the periscope will indicate the condition and the care and treatment it has received. Check for damaged, cracked, or dented surfaces, bent or broken parts, moisture and corrosion, and other evidence of damage or misuse that might indicate a need for repair.

c. The mounting surfaces shall not be damaged in any way that would prevent the proper seating of the periscope in its adapters.

d. The crash pad shall not be deteriorated, cut, or torn. It should be bonded securely to the housing.

e. The metal cover shall not be damaged in any way that would cause leaks. Inspect welds for cracks or breaks.

f. The clamping knob on the periscope shall rotate freely on the stud, and hold the periscope securely when tightened against the segment.

g. The screw on the segment should operate smoothly with normal hand pressure when the clamping knob is released. Segment shall not be bent or broken.

h. The painted surfaces shall be inspected for bare spots, chips, or cracks which expose metal surfaces that could lead to corrosion. Determine if finish warrants touchup or complete refinishing. Refer to TM 9-213.

i. The metal housing on the periscope shall not be bent or twisted, and there shall be no undue looseness between the housing and the periscope body. Inspect welds for cracks or breaks.

j. When viewing through the periscope the r e shall be no objectionable dirt, smears, scratches, digs, condensate, fungus growth, chips, or fractures.

Note: Rejection shall be based only on those defects which are apparent when the periscope is used in a manner simulating actual use.

k. The windows and mirrors of the periscope shall be firmly cemented and shall show no signs of separation from the plastic body.

l. The sealing compound, 8030-275-8110, MIL-S-11031A (ORD), shall show no signs of deterioration.

m. Check organizational repair parts and equipment for general condition, method of storage, and procedures for obtaining replacements.

n. Investigate mechanical and functional difficulties that troops may be experiencing. Check for determinable causes, such as inadequate design, poor workmanship or material, lack of knowledge, misinformation, neglect, or improper storage, or preservation.

o. Instruct the using personnel in supply and preventive maintenance procedures if the need for such instruction is necessary.

CHAPTER 4

REPAIR AND OVERHAUL

Section I. GENERAL

16. Scope

This chapter contains specific maintenance instructions for field and depot repair and overhaul of periscope M37 when the equipment does not meet the serviceability inspections. The scope of field and depot maintenance is determined by the listing of field and depot maintenance repair parts and special tools in TM 9-1240-315-35P and the maintenance allocation chart in TM 9-2350-215-20.

17. Maintenance Technique

Whenever possible repair is to be accomplished in the vehicle. The maintenance technique IROAN, as defined in paragraph 3, will be adhered to.

18. References

a. *General.* TM 9-254 presents those general maintenance procedures that are most often encountered in repairing fire control materiel. These procedures are presented as guides to maintenance per-

sonnel in the performance of their duties. Organizational maintenance of the periscope is covered in TM 9-2350-215-20.

b. *Cleaning and Drying.* Optics shall be cleaned and dried. Other surfaces shall be cleaned by process CI of MIL-P-116C and dried as specified in MIL-P-116C.

c. *Lubrication.* Lubricate mounting surfaces and threaded surfaces with a very light film of aircraft and instrument grease, 9150-261-8298, MIL-G-3278. Lubrication can be accomplished using a cloth impregnated with grease. Remove all surplus grease.

d. *Sealing.* Periscope M37 is sealed with sealing compound.

e. *Final Protective Finish.* All sheet metal surfaces, requiring touchup or repainting, are to have finish No. 5.1 and system No. 21.5 of MIL-STD-171A (ORD) O. D., color No. 24087 of FED-STD 595. Painting instructions in TM 9-213. MIL-STD-194 (ORD) references finish, system, and color.

Note: Surfaces which require this finish are: cover 8635078 and housing 8635085.

Section II. REPAIR AND OVERHAUL OF PERISCOPE M37

19. Scope

When component parts (fig. 2) do not operate properly, are missing, or broken they shall be replaced. Optical component parts are not authorized for replacement, repair, or overhaul.

20. Disassembly and Assembly

Periscope M37 (fig. 2) will require a minimum of disassembly and assembly.

Note: The key numbers shown below in parentheses refer to figure 2.

a. *Disassembly.* Remove 1/4 retaining ring (1) and 0.281 washer (2), unscrew knob (3) and remove 3/8 spring washer (4) and 5/16 washer (5) from stud in housing. Remove 1/4-28UNF-2A x 0.875 knurled head screw (6) and 15/32 retaining ring (7) and then remove segment (8) from pin and stud.

b. *Assembly.* Replace segment (8) by

placing slot over stud and the top opening over trunnion pin, secure with ring (7), insert and tighten screw (6), place washer (5) and washer (4) on stud, screw on knob (3) and secure with washer (2) and ring (1).

21. Final Inspection

Final inspection is performed after all necessary repair has been completed to insure that the materiel is serviceable according to the established standards. Refer to paragraphs 10 through 15 for detailed inspection procedures.

CHAPTER 5

PROCESSING AND PACKAGING

22. Specifications

Periscope M37 shall be processed and packed in accordance with levels A, B, and C shown in packaging specification MIL-F-14619/P8635100, TM 9-200 (boxed material), and TB 9-299/1 (unboxed material).

23. Optical Components

a. Optics shall be cleaned and dried (para 19b).

b. Cover all windows or optical elements with at least four thicknesses of neutral lens tissue and secure in place with water-resistant pressure-sensitive tape. Cover the lens tissue with cellulosic material and secure in place with pressure-sensitive tape.

c. A piece of cushioning (6-3/4 x 3 x 1/4) shall be placed over each tissue covered glass and secured in place with two pieces of tape (1/2 x 6) per cushion.

APPENDIX

REFERENCES

1. Publication Indexes

The following publication indexes should be consulted frequently for latest changes or revisions of references given in the appendix and for new publications relating to materiel covered in this manual.

Index of Army Motion pictures, Film Strips, Slides, and Phono-Recordings.	DA Pam 108-1
Military Publications:	
Index of Administrative Publications	DA Pam 310-1
Index of Blank Forms	DA Pam 310-2
Index of Graphic Training Aids and Devices	DA Pam 310-5
Index of Supply Manuals; Ordnance Corps	DA Pam 310-29
Index of Tables of Organization and Equipment, Tables of Organization, Type Tables of Distribution, and Tables of Allowances.	DA Pam 310-7
Index of Technical Manuals, Technical Bulletins, Supply Bulletins, Lubrication Orders, and Modification Work Orders.	DA Pam 310-4
Index of Training Publications.	DA Pam 310-3

2. Supply Manuals

The following supply manuals of the Department of the Army Supply Manuals pertain to this materiel:

<i>a. Destruction to Prevent Enemy Use.</i>	
Ammunition and Explosives (Class 1375 Explosives, Solid Propellants and Explosive Devices).	SM 9-5-1375
<i>b. Repair and Overhaul.</i>	
Brushes, Paints, Sealers, and Adhesives	SM 5-1-C5-1
Fire Control Maintenance and Repair Shop Specialized Equipment: Tool Set, Depot Maintenance, Supplementary Tools, Fixtures and Equipment (4931-798-7583).	SM 9-4-4931-J40
Fire Control Maintenance and Repair Shop Specialized Equipment Tool Set, Field and Depot Maintenance, General Purpose, Special Tools (4931-574-6433),	SM 9-4-4931-J51
Fire Control Maintenance and Repair Shop Specialized Equipment Tool Set, Special Depot Maintenance, Optical Cleaning, Coating, Cementing and Decementing (4931-535-7827).	SM 9-4-4931-J48
Fire Control Maintenance and Repair Shop Specialized Equipment Wrench Set, Spanner, Field and Depot Maintenance, Tubr, Dble-End Concave Inserted Blade, Set of 76 Wrenches (4931-580-0012).	SM 9-4-4931-J52
Fuels, Lubricants, Oils and Waxes	SM 10-1-C4-1
Hardware and Abrasives.	SM 9-1-C5300
Maintenance and Repair Shop Equipment.	SM 9-1-4910
Tool Kit, Fire Control Repairman (5180-357-7735)	SM 9-4-5180-A61
Tool Kit, Instrument Repairman's (5180-357-7743)	SM 9-4-5180-A62

3. Forms

The following forms pertain to this materiel:

DA Form 9-1, Materiel Inspection Tag

DA Form 9-12, Inspection of Ordnance Equipment
 DA Form 9-79, Parts Requisition
 DA Form 9-80, Job Order File
 DA Form 828, Job Time Ticket - Individual
 DA Form 829, Rejection Memorandum
 DA Form 1115, Property Turn-In Tag
 DA Form 1296, Stock Accounting Record
 DA Form 1297, Title Insert (Formal Accountability)
 DA Form 1546, Request for Issue or Turn-In
 DA Form 2028, Recommended Changes to DA Technical Manual Parts Lists or Supply
 Manual 7, 8, or 9
 DA Form 2405, Maintenance Request Register
 DA Form 2407, Maintenance Request
 DD Form 6, Report of Damaged or Improper Shipment
 DD Form 250, Materiel Inspection and Receiving Report

4. Other Publications

a. Camouflage.

Camouflage, Basic Principles and Field Camouflage ----- FM 5-20

b. Decontamination.

Chemical, Biological, and Radiological (CBR) Decontamination -- TM 3-220
 Small Unit Procedures in Nuclear, Biological, and Chemical Warfare FM 21-40

c. Destruction to Prevent Enemy Use.

Explosives and Demolitions ----- FM 5-25
 Ordnance Ammunition Service - - - - - FM 9-5
 Ordnance Service in the Field - - - - - FM 9-1
 Safety: Regulations for Firing Ammunition for Training, Target Practice, and Combat. AR 385-63/
 AFR 50-13

d. General.

Dictionary of United States Army Terms - - - - - AR 320-5
 Logistics (General); Malfunctions Involving Ammunition and Explosives (Reports Control Symbol ORD-43), AR 700-1300-8
 Maintenance of Supplies and Equipment: Organization, Policies, and Responsibilities for Maintenance Operation. AR 750-5
 Military Symbols - - - - - FM 21-30/
 AFM 55-3

Military Terms, Abbreviations, and Symbols:

Authorized Abbreviations and Brevity Codes - - - - - AR 320-50
 Military Training - - - - - FM 21-5
 Ordnance Direct Support Services - - - - - FM 9-3
 Ordnance General and Depot Support Services - - - - - FM 9-4
 Principles of Fire Control Materiel - - - - - TM 9-3305-2
 Safety: Accident Reporting and Records - - - - - AR 385-40
 Shop Mathematics - - - - - TM 9-2820
 Techniques of Military Instruction - - - - - FM 21-6
 The Army Equipment Record System and Procedures - - - - - TM 38-750

e. Maintenance.

Cleaning of Ordnance Materiel - - - - - TM 9-208-1
 Field and Depot Maintenance Repair Parts and Special Tool Lists for Periscope M37. TM 9-1240-315-35P
 General Maintenance Procedures for Fire Control Materiel - - - TM 9-254

Grease Aircraft and Instrument (For Low and High Temperature).	MIL-G-3278
Inspection of Ordnance Materiel in Hands of Troops - - - - -	TM 9-1100
Lubricating Oil: Aircraft Instrument, Low Volatility - - - - -	MIL-L-6085A(2)
Lubrication of Ordnance Materiel - - - - -	TM 9-273
Maintenance of Supplies and Equipment: Command Maintenance Inspections.	AR 750-8
Materials Used for Cleaning, Preserving, Abrading, and Cementing Ordnance Materiel; and Related Materials Including Chemicals.	TM 9-247
Operation and Maintenance of Ordnance Materiel in Extreme Cold Weather, 0° to -65° F.	TM 9-207
Operator's Manual: Tank, Combat, Full Tracked: 105-mm Gun, M60 (2350-678-5773); Trainer, Tank Gunnery: Medium, XM30 (6920-790-2259).	TM 9-2350-215-10
Optical Characteristics - - - - -	MIL-P-46329(ORD)
Ordnance Maintenance: Operation and Maintenance of Optical Coating Equipment:	TM 9-1501
Organizational Maintenance Manual: Tank, Combat, Full Tracked: 105-mm Gun, M60 (2350-678-5773).	TM 9-2350-215-20
Painting and Finishing Systems for Fire Control Instruments - -	MIL-STD-194(ORD)
Painting Instructions for Field Use - - - - -	TM 9-213
Preparation, Painting, and Finishing for Metal and Wood Surfaces.	MIL-STD-171A(ORD)
Sealing Compound - - - - -	MIL-S-11031A(ORD)
Special Operations: Northern Operations - - - - -	FM 31-71
Technical Procedures: Elementary Optics and Application to Fire Control Instruments.	TM 9-258
Use and Care of Handtools and Measuring Tools - - - - -	TM 9-243
<i>f. Operations.</i>	
Auxiliary Sighting and Fire Control Equipment - - - - -	TM 9-575
Ordnance Corp Equipment Data Sheets - - - - -	TM 9-500
<i>g. Shipment and Storage.</i>	
Fire Control Parts, Equipment and Tools: Packaging of.	MIL-F-14619/ P8635100
General Packaging Instructions for Ordnance General Supplies	TM 9-200
Issue of Supplies and Equipment: Preparation, Processing, and Documentation for Requisitioning, Shipping, and Receiving.	AR 725-5
Logistics (General): Preservation, Packaging, and Packing - - - -	AR 700-15
Logistics (General): Report of Damaged or Improper Shipment	AR 700-58
Marking and Packing of Supplies and Equipment: Marking of Supplies for Shipment.	AR 746-80
Preservation, Methods of - - - - -	MIL-P-116C
Processing of Unboxed Self-Propelled and Towed Class II Ordnance General Supplies and Related Materiel for Shipment and Storage.	TB 9-299/1
Protection of Ordnance General Supplies in Open Storage - - - -	TB ORD 379
Standards for Oversea Shipment and Domestic Issue of Ordnance Materiel Other Than Ammunition and Army Aircraft.	TB ORD 385
Storage of Supplies and Equipment: Storage and Materials Handling.	TM 743-200-1

By Order of Secretary of the Army:

EARLE G. WHEELER,
*General, United States Army,
Chief of Staff.*

Official:

J. C. LAMBERT,
*Major General, United States Army,
The Adjutant General.*

Distribution:

Active Army:

CNGB (1)	Benicia Arsenal (2)
Sup & Maint Comd (12)	Frankford Arsenal (10)
USA Ord CD Agcy (1)	Red River Arsenal (2)
USCONARC (3)	Rock Island Arsenal (2)
ARADCOM (2)	Units org under fol T O E
ARADCOM Rgn (2)	(2 copies)
OS Maj Cored (2)	9-7
Base Cored (2)	9-9
LOGCOMD (1)	9-12
Armies (3)	9-25
Corps (2)	9-26
USA Corps (2)	9-27
Anniston A Dep (2)	9-57
Erie A Dep (2)	9-65
Letterkenny A Dep (2)	9-66
Mt Rainier A Dep (2)	9-67
Pueblo A Dep (2)	9-76
Tooele A Dep (2)	9-167
Raritan Arsenal (10)	9-500 (BA,FA,EC,LA)

NG: None.

USAR: Same as active army except allowance is one copy to each unit.

For explanation of abbreviations used, see AR 320-50.

